

**CyberData** The IP Endpoint Company  
**Ceiling Mount**  
**010991**



Features

- Easy tile ceiling installation
- Electrogalvanized steel construction
- RoHS compliant
- Two years warranty

Product Components List

- (1) Mount, ceiling tile reinforcement

Dimensions

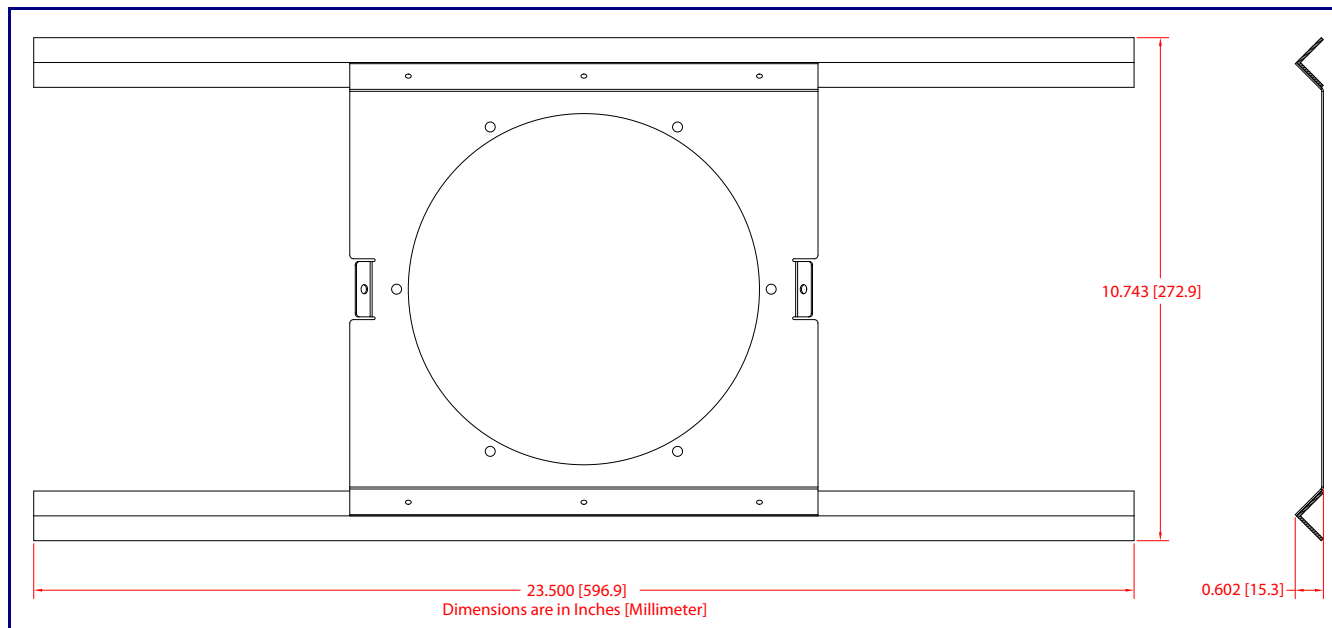

## Exploded View

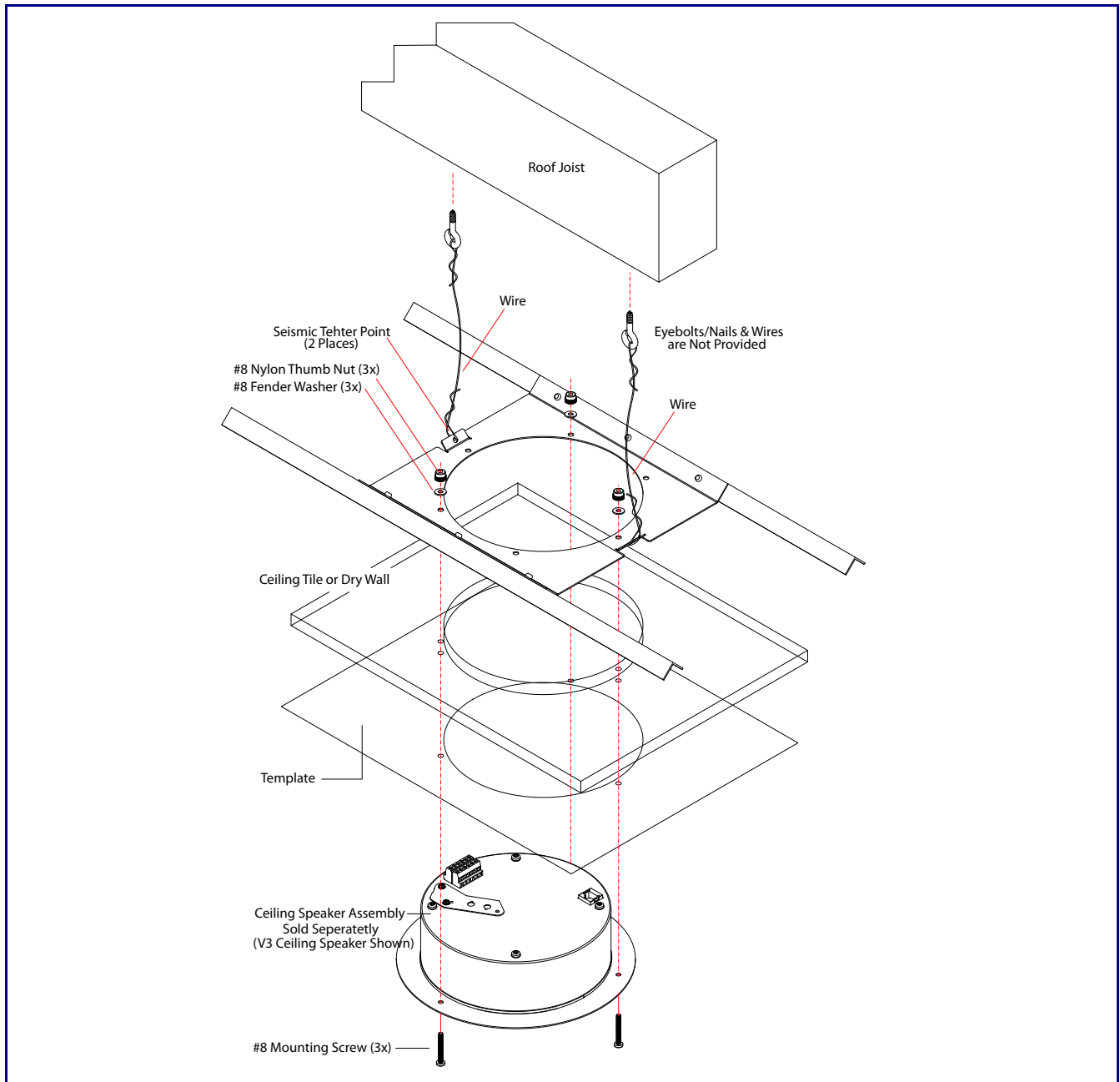

## Contacting CyberData

### Corporate Headquarters

CyberData Corporation  
3 Justin Court  
Monterey, CA 93940, USA

Phone: 831-373-2601  
Fax: 831-373-4193  
<http://www.cyberdata.net/>

Sales: (831) 373-2601 ext. 334  
Support: 831-373-2601 ext. 333  
Support Website: <http://support.cyberdata.net/>  
RMA Department: (831) 373-2601 ext. 136  
RMA Email: [RMA@CyberData.net](mailto:RMA@CyberData.net)  
RMA Status: <http://support.cyberdata.net/>  
Warranty Information: <http://support.cyberdata.net/>