

Contacting CyberData

<p>Corporate Headquarters</p> <p>CyberData Corporation 2555 Garden Road Monterey, CA 93940, USA</p> <p>Phone: 831-373-2601 Fax: 831-373-4193 www.CyberData.net</p> <p>Sales: (831) 373-2601 ext. 334</p> <p>Support: 831-373-2601 ext. 333 Email: support@CyberData.net</p> <p>RMA Dept: (831) 373-2601 ext. 136 Email: RMA@CyberData.net</p>	<p>Warranty</p> <p>CyberData warrants its product against defects in material and workmanship for a period of two years from the date of purchase. Should the product fail within the warranty period, CyberData will repair or replace the product free of charge. This warranty includes all parts and labor. Should the product fail out-of-warranty, a flat rate repair charge of one half the purchase price will be assessed. Repair costs for products that are in warranty, but damaged by improper modifications or abuse, are charged at the out-of-warranty rate. Products returned to CyberData, both in and out-of-warranty, are shipped to CyberData at the customer's expense. Charges for shipping repaired products to the customer are paid by CyberData.</p> <p>For product service, contact the Returned Materials Authorization (RMA) department. A product will not be accepted for return without an approved RMA number. Send the product, in its original package, to: CyberData Corporation, 2555 Garden Road, Monterey, CA 93940, Attention: RMA "your RMA number"</p>
---	--



Installation Quick Reference
VoIP Intercom
 SIP Compliant
010935



Parameter	Factory Default Setting
IP Addressing	DHCP
IP Address ^a	10.10.10.10
Web Access Username	admin
Web Access Password	admin
Subnet Mask ^a	255.0.0.0
Default Gateway ^a	10.0.0.1

^a. Use if there is not a DHCP server present.



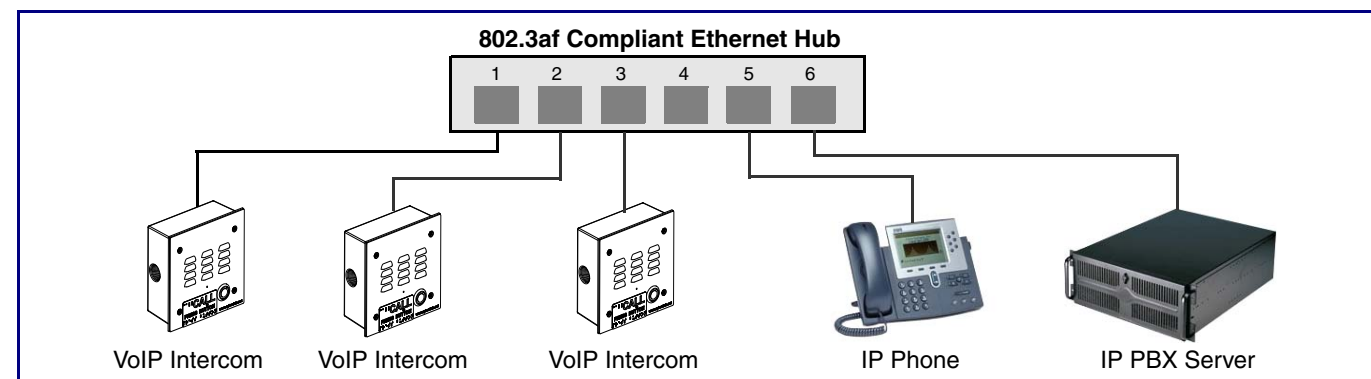

Typical Intercom System Installation

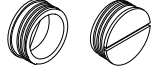

Getting Started

- Download the *VoIP Intercom Operations Guide* PDF file, from the VoIP Intercom product page at: <http://www.cyberdata.net/support/voip/index.html>
- Create a plan for the locations of your Intercoms.
- Prior to installation, consult local building and electrical code requirements.
- **WARNING: This enclosure is not rated for any AC voltages!**

Intercom Parts

<p>(1) Intercom Assembly</p> 	<p>(1) Wall Mounting Kit</p> <p>(2) Outlet box plugs </p> <p>(2) Flush mounting plate </p>	<p>(2) 8-32 x 1/4" Flat head phillips machine screw </p> <p>(1) 10-24 x 5/16" Pan head phillips machine screw </p>
---	---	--

Intercom Assembly

To mount the intercom, use methods compliant with local electrical codes.

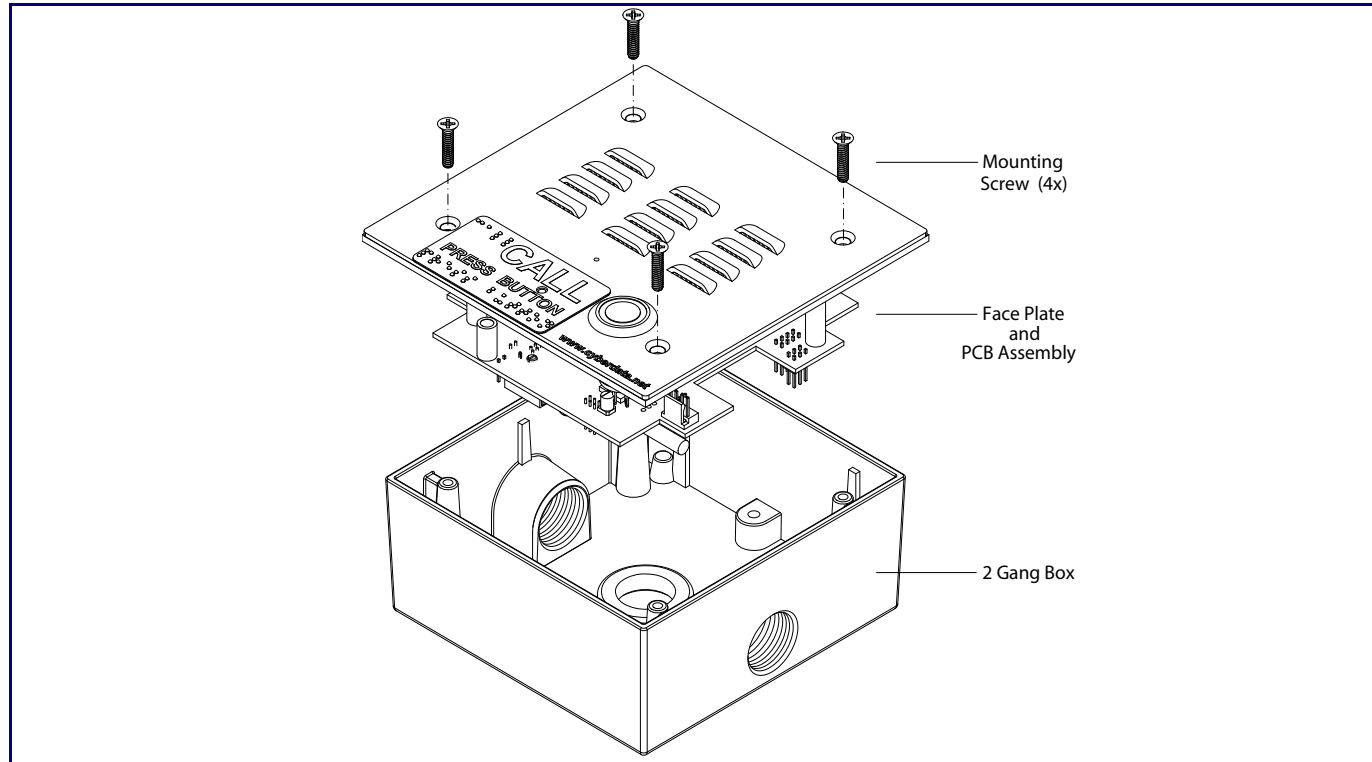

Intercom Dimensions

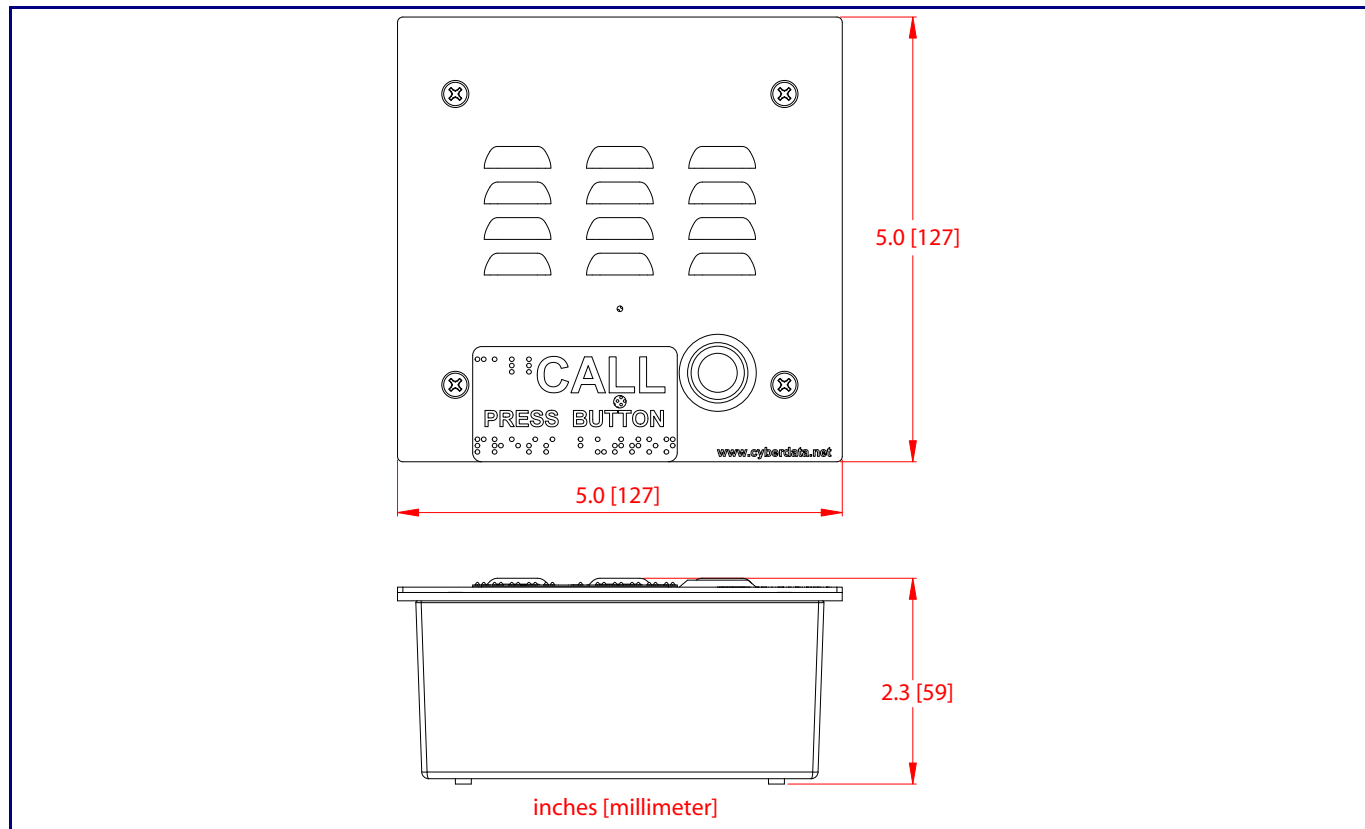

Cable Entries and Conduit Restrictions

The VoIP Intercom has three possible cable entries. If you are using the center entry, refer to the drawing on the right that shows the entry restrictions.

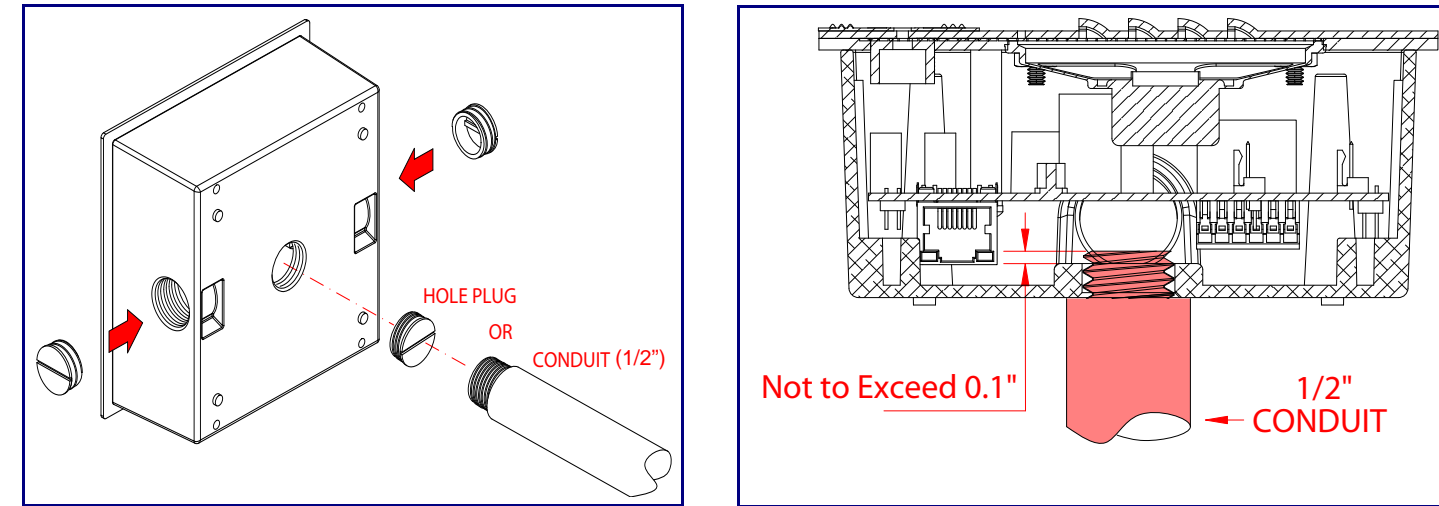

Mounting and Screws

